

N Connectors Series



Content.....	Page
Description	2
Interface Dimensions	2
Interface Dimensions in mm/inches	2
Characteristics	3
Cable Connectors	4
PCB Connectors	8
Panel Receptacles	9
Adapter Connectors	13
Termination	19
Assembly Instruction	20

Description

The Type N connector was developed in the 1940's to satisfy the need for a durable, weatherproof, medium-size RF connector with consistent performance through 11 GHz. N series connector has been a staple in RF and Microwave applications all over the world. It is suited to a vast range of applications from military and aerospace to wireless LAN.

Interface Dimensions

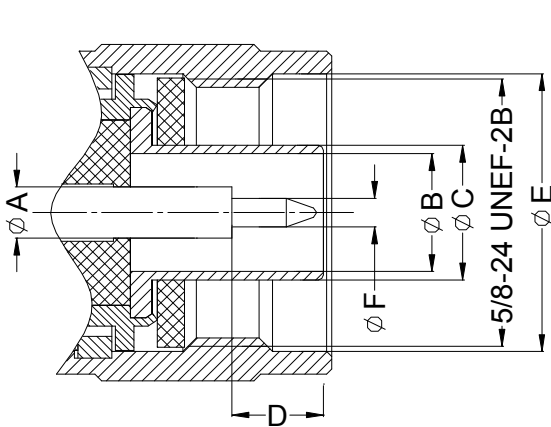

Plug (male)

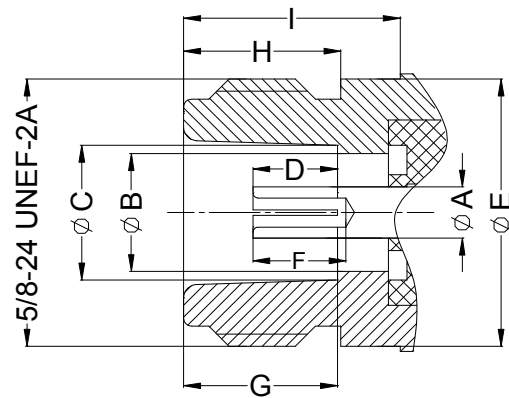

Jack (female)

Interface Dimensions (mm/inches)

	Plug		Jack	
	min.	max.	min.	max.
A	-	3.06/.120	-	3.15/.124
B	6.98/.275	7.02/.276	-	7.06/.278
C	-	8.00/.315	8.03/.316	8.13/.320
D	5.33/.210	5.84/.230	4.75/.187	5.26/.207
E	16.00/.630	-	-	15.93/.627
F	1.60/.063	1.68/.066	5.33/.210	-
G	-	-	9.04/.356	9.19/.362
H	-	-	6.76/.266	-
I	-	-	10.72/.422	-

Interface dimensions conformable to the standards:

International: **IEC 61169-16**

Europe: **CECC 22 210**

USA: **MIL-STD-348A/304**

Characteristics

ELECTRICAL	REQUIREMENTS
Impedance	50
Frequency range	DC to 18 GHz
Dielectric Withstanding Voltage	2500 V rms 50 Hz, sea level
Working Voltage	≤1,000 V rms 50 Hz, sea level
VSWR	Straight connector, .141": ≤1.29 (DC~11GHZ)
	Straight connector, RG316: ≤1.21 (DC~6GHZ)
	Right angle connector, .141": ≤1.38 (DC~11GHZ)
	Right angle connector, RG316: ≤1.30 (DC~6GHZ)
Insulation Resistance	5×10 ³ MΩ min.(initial)
Contact Resistance	
- Center contact	1.0 m max..
- Outer contact	1.0 m max.
RF-leakage	
DC to 3 GHz	-90 dB min.
3 GHz to 6 GHz	-75 dB min.

MECHANICAL	REQUIREMENTS
Coupling Nut Torque	
- Recommended	0.68 Nm~1.13 Nm / 6.0~10.0 in. lbs
- Proof torque	1.70 Nm /15.0 in. lbs
Coupling Nut Retention Force	≥450 N /101.2 lbs
Contact Captivation	≥ 28 N/6.3 lbs
Cable Retention Force	
- cable 5/50	150 N/33.75 lbs (single braid) 200 N/48 lbs (double braid)
-cable 10.5/50	300 N/67.5 lbs
-cable 11/50	400 N/90 lbs
-cable .141	270 N/60.75 lbs
Durability (Mating Cycles)	500 min.

ENVIRONMENTAL	REQUIREMENTS
Temperature Range	-55°C to +155°C
Climactic Category	IEC→55/155/21
Corrosion	Salt spray test acc. to MIL-STD-202, Method 101, Condition B
Moisture Resistance	MIL-STD-202 F, Method 106 F
Vibration	IEC-1169-1 Paragraph9.3.3(10-500 Hz;5g)
Shock	MIL-STD-202, Method 213, Condition I

Note: The above characteristics are typical but may not apply to all connectors.

Cable Connectors

Straight Cable Plugs (male)

>for semi-rigid cables

Part No.	Cable Group (Example)	Finish	Remarks	Assembly Instruction
ANO 5111-2034	.141/50 (SMT680-141/RG402)	Passivated	Solder	AI 01

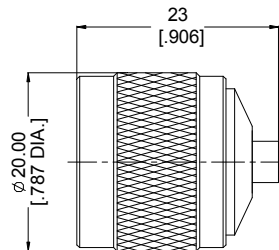

>for flexible cables

Part No.	Cable Group (Example)	Finish	Remarks	Assembly Instruction
ANO 5111-2039	2/50/S (RG178)	Nickel	Solder	AI 02

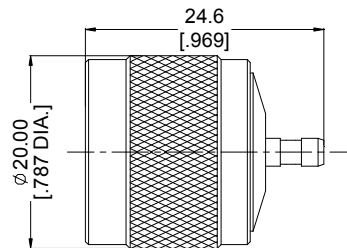

>for flexible cables

Part No.	Cable Group (Example)	Finish	Remarks	Assembly Instruction
ANO 5111-2006	2.6/50/S/D (RG316/LMR100)	Nickel	Crimp	AI 03

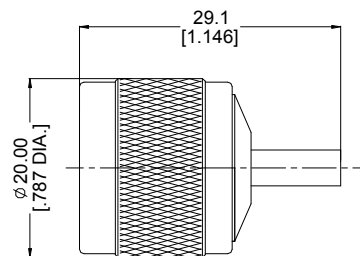

>for flexible cables

Part No.	Cable Group (Example)	Finish	Remarks	Assembly Instruction
ANO 5111-2007	5/50/S/D (RG58/LMR195)	Nickel	Crimp	AI 03
ANO 5111-2002	5/50/S/D (RG58/LMR200)	Nickel	Crimp	AI 03

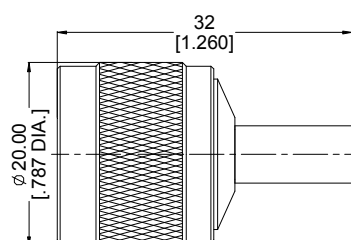

>for flexible cables

Part No.	Cable Group (Example)	Finish	Remarks	Assembly Instruction
ANO 5111-2003	6/50 /D (LMR240)	Nickel	Crimp	AI 03

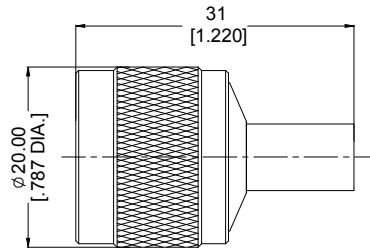

>for flexible cables

Part No.	Cable Group (Example)	Finish	Remarks	Assembly Instruction
ANO 5111-2037	7.5/50 /D (LMR300)	Nickel	Crimp	AI 03

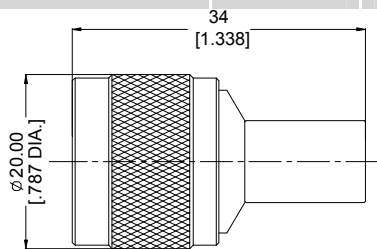

>for flexible cables

Part No.	Cable Group (Example)	Finish	Remarks	Assembly Instruction
ANO 5111-2001	10.5/50 /D (LMR400)	Nickel	Crimp	AI 03

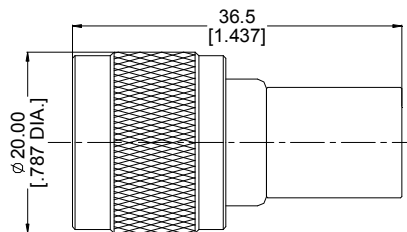

>for flexible cables

Part No.	Cable Group (Example)	Finish	Remarks	Assembly Instruction
ANO 5111-2028	15/50 /D (LMR600)	Nickel	Crimp	AI 03

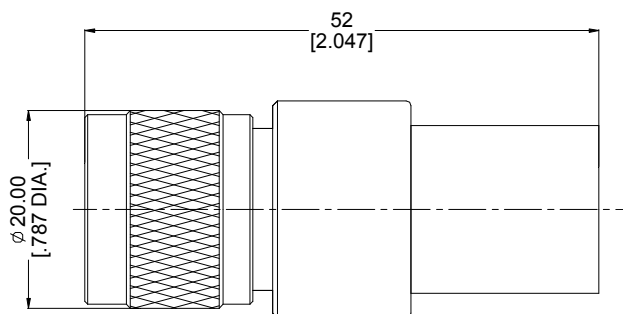

Right Angle Cable Plugs (male)

>for flexible cables

Part No.	Cable Group (Example)	Finish	Remarks	Assembly Instruction
ANO 5121-2041	7.5/50 /D (LMR300)	Nickel	Crimp	AI 05

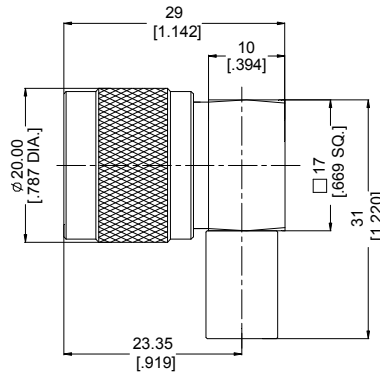

>for flexible cables

Part No.	Cable Group (Example)	Finish	Remarks	Assembly Instruction
ANO 5121-2040	10.5/50 /D (LMR400)	Nickel	Clamp	AI 06

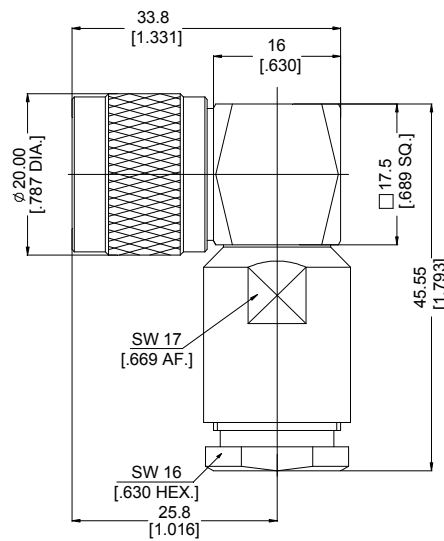

Straight Cable Jacks (female)

>for flexible cables

Part No.	Cable Group (Example)	Finish	Remarks	Assembly Instruction
ANO 5112-2038	7.5/50 /D (LMR300)	Nickel	Crimp	AI 04

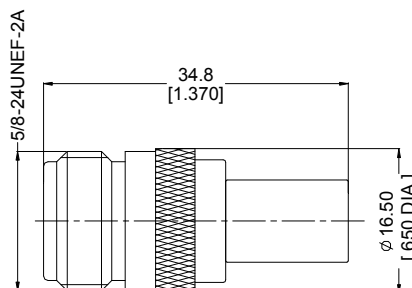

>for flexible cables

Part No.	Cable Group (Example)	Finish	Remarks	Assembly Instruction
ANO 5112-2025	10.5/50 /D (LMR400)	Nickel	Crimp	AI 04

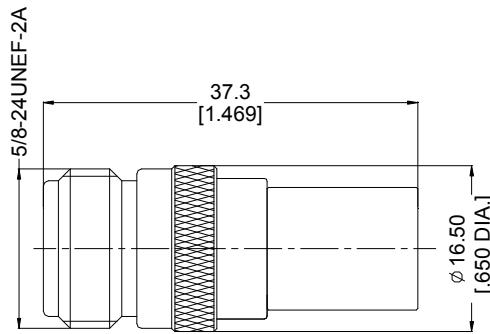

Straight Bulkhead Cable Jacks (female)

>for semi-rigid cables

Part No.	Cable Group (Example)	Finish	Remarks	Assembly Instruction /Mounting Hole	Fig.
ANO 5112-1018	.083/.085/50 (SMT680-086/RG405)	Nickel	Solder	AI 01/MH 5	1
ANO 5112-1024	.083/.085/50 (SMT680-086/RG405)	Nickel	Solder	AI 01/MH 5	2

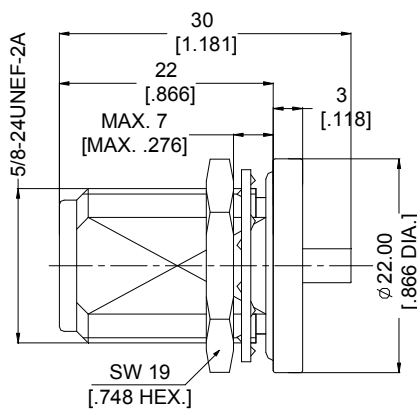

Fig.1

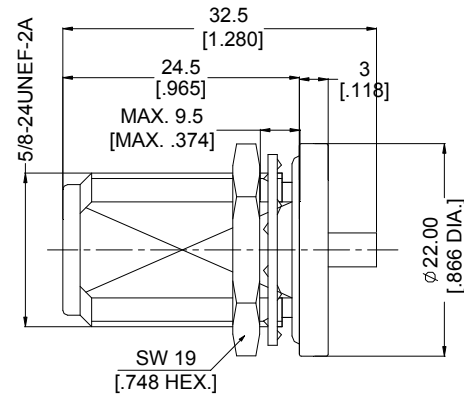
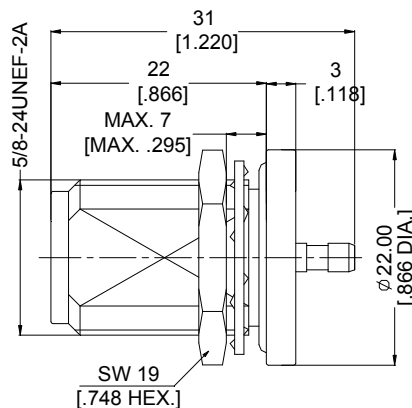

Fig.2

>for flexible cables

Part No.	Cable Group (Example)	Finish	Remarks	Assembly Instruction /Mounting Hole
ANO 5112-1008	2/50/S (RG178)	Nickel	Solder	AI 07/MH 5



>for flexible cables

Part No.	Cable Group (Example)	Finish	Remarks	Assembly Instruction/Mounting Hole
ANO 5112-1010	2.6/50/S/D (RG316/LMR100)	Nickel	Crimp	AI 08/MH 5

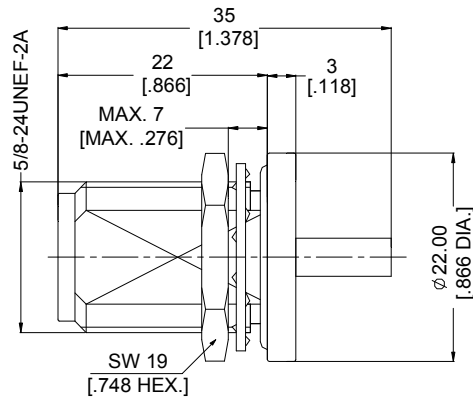

>for flexible cables

Part No.	Cable Group (Example)	Finish	Remarks	Assembly Instruction/Mounting Hole
ANO 5112-1009	5/50/S/D (RG58/LMR195)	Nickel	Crimp	AI 08/MH 5

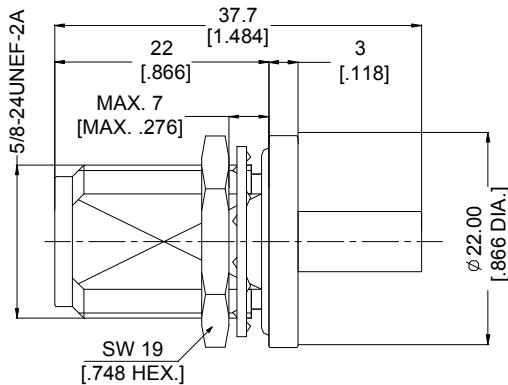

PCB Connectors

Straight PCB jacks (female)

Part No.	Finish	PCB Pattern
ANO 5112-5031	Nickel	MH 13

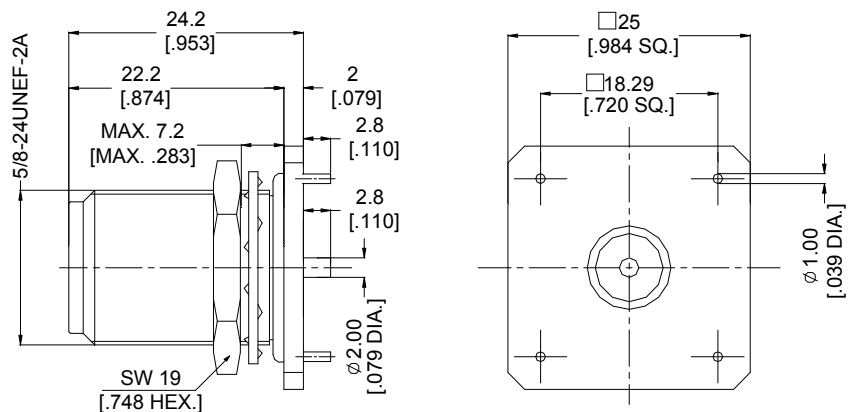

Right Angle PCB jacks (female)

Part No.	Finish	PCB Pattern
ANO 5122-4026	Nickel	MH 18

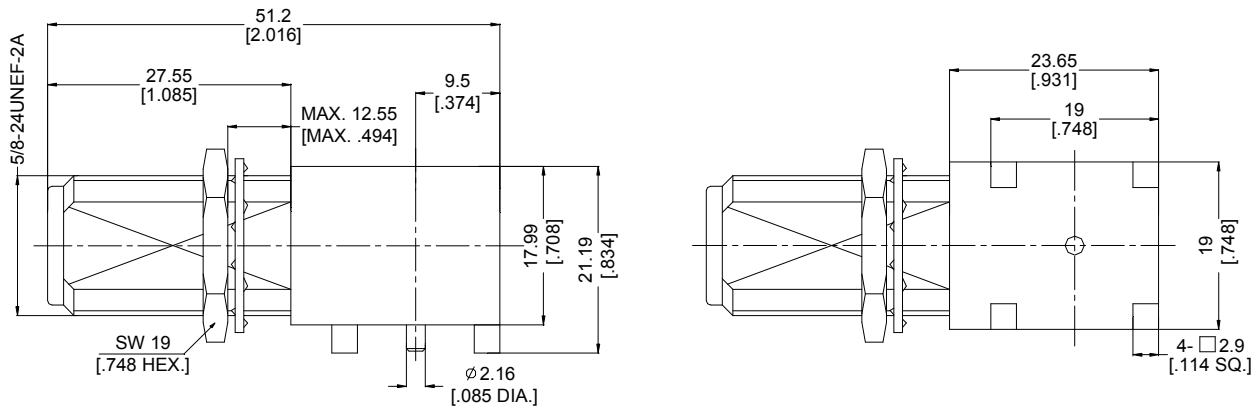

Panel Receptacles

Receptacles, plugs (male)

Part No.	Finish	Mounting Hole
ANO 5111-3004	Nickel	MH 8

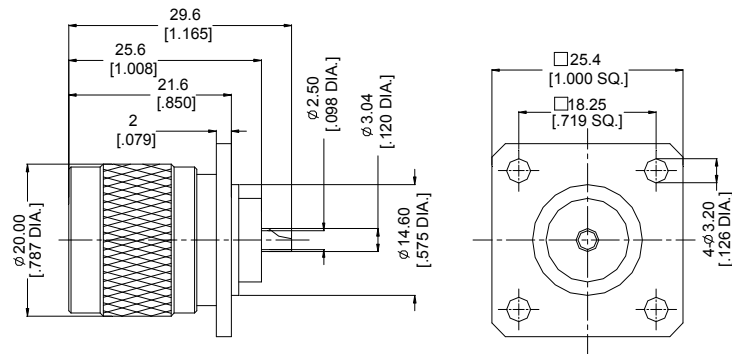

Receptacles, jack (female)

Part No.	Finish	Mounting Hole
ANO 5112-5013	Nickel	MH 5

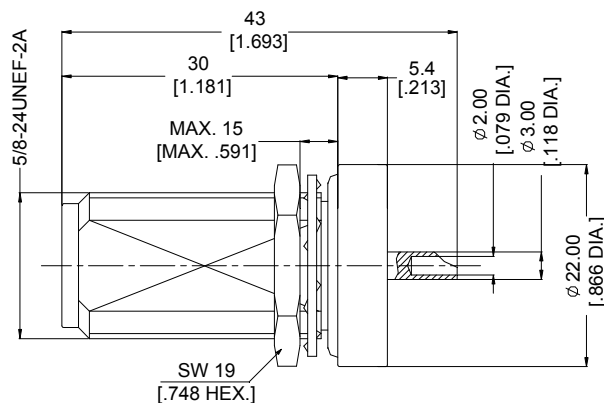

Receptacles, jack (female)

Part No.	Finish	Mounting Hole
ANO 5112-1042	Nickel	MH 5

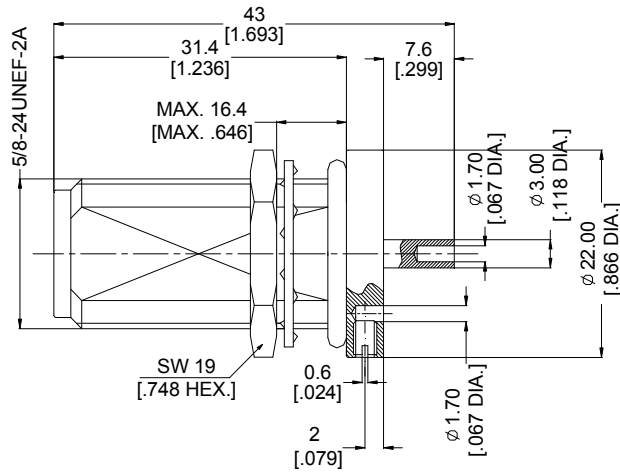

Receptacles, jack (female)

Part No.	Finish	Mounting Hole
ANO 5112-3011	Nickel	MH 7

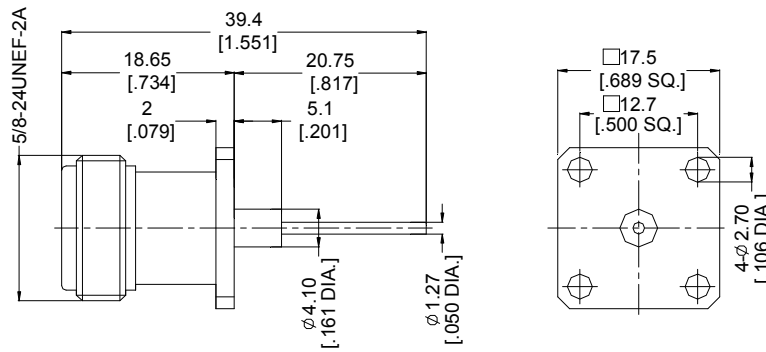

Receptacles, jack (female)

Part No.	Finish	Mounting Hole
ANO 5112-3012	Nickel	MH 12

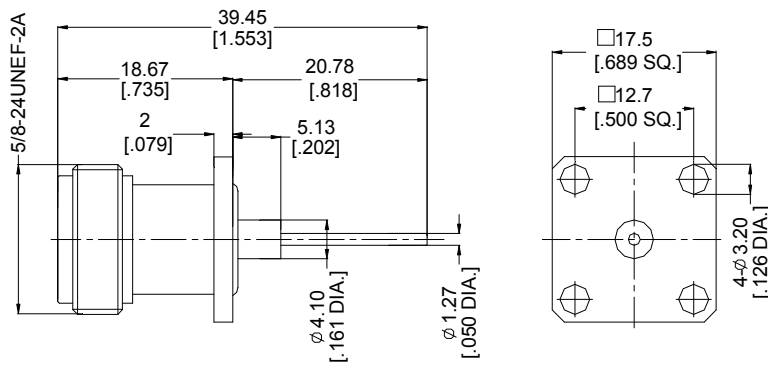

Receptacles, jack (female)

Part No.	Finish	Mounting Hole
ANO 5112-3023	Nickel	MH 8
ANO 5112-3035	Albaloy	MH 8

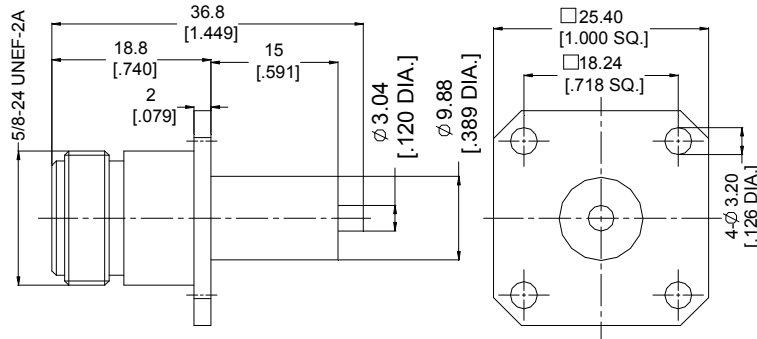

Flat tab receptacles, jack (female)

Part No.	Finish	Dimensions	Mounting Hole
ANO 5112-3015	Nickel	A=0.25/.010	MH 12
ANO 5112-3020	Nickel	A=0.13/.005	MH 12

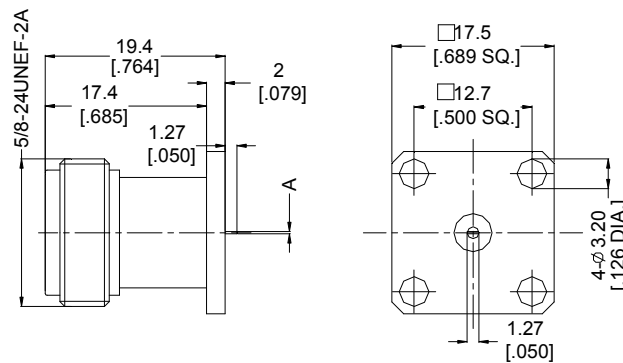

Slot receptacles, jack (female)

Part No.	Finish	Mounting Hole
ANO 5112-3021	Nickel	MH 8

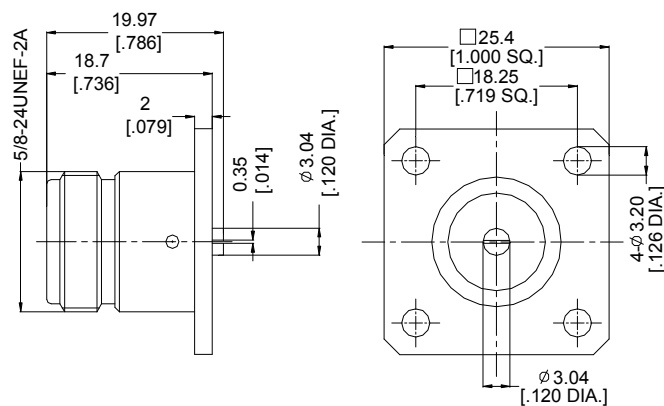

Adapter Connectors

Adapter plug/plug (male/male)

Part No.	Finish	Type / Type
ANO 511-511-1009	Nickel	N(plug) / N(plug)

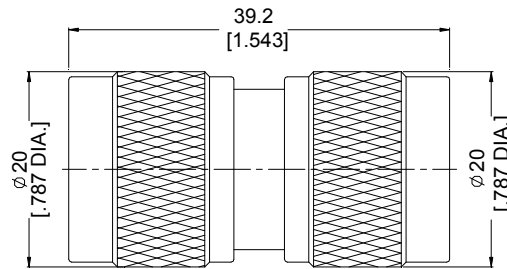

Adapter plug/plug (male/male)

Part No.	Finish	Type / Type
ANO 511-333-1017	Nickel	N(plug) / RP TNC(plug)

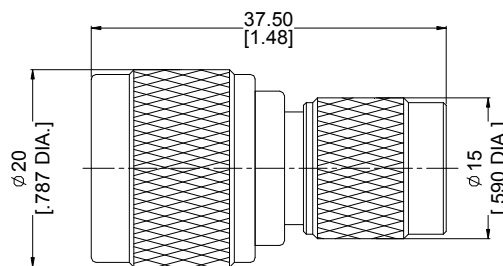

Adapter plug/plug (male/male)

Part No.	Finish	Type / Type
ANO 511-261-1033	Nickel	N(plug) / QMA(plug)

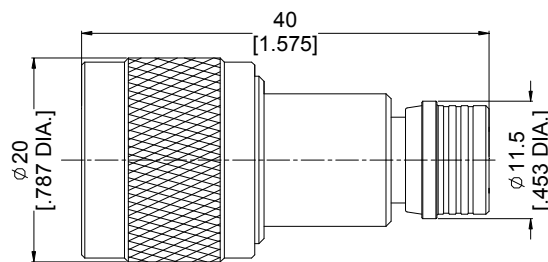

Adapter plug/plug (male/male)

Part No.	Finish	Type / Type
ANO 511-281-1055	Nickel	N(plug) / Mini-QMA(plug)

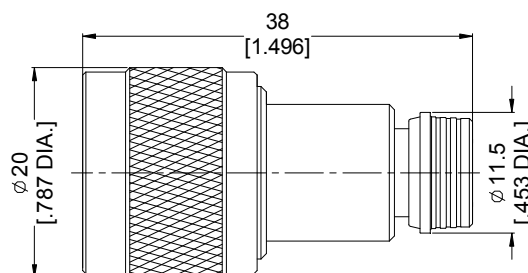

Adapter plug/plug (male/male)

Part No.	Finish	Type / Type
ANO 511-531-1044	Nickel	N(plug) /HPQN(plug)

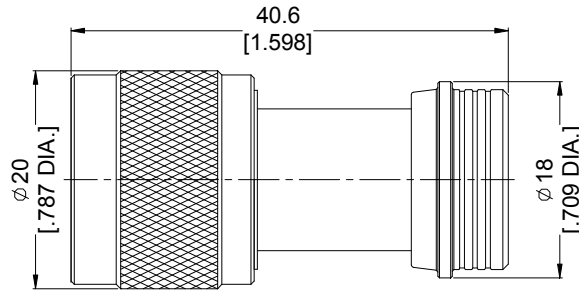

Bulkhead Adapter jack/jack (female/female)

Part No.	Finish	Type / Type	Mounting Hole
ANO 512-512-1022	Nickel	N(jack) /N(jack)	MH 5

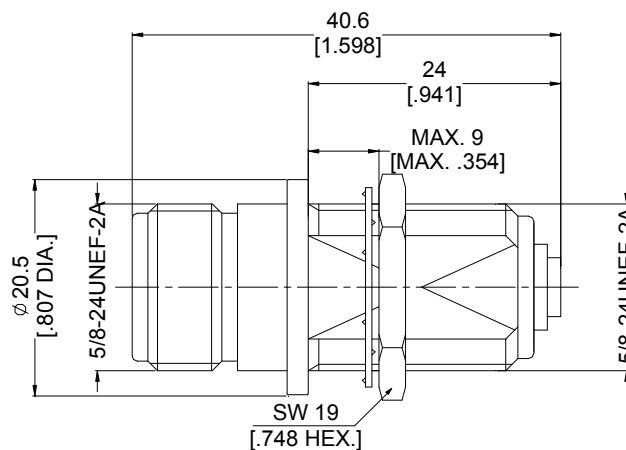

Bulkhead Adapter jack/jack (female/female)

Part No.	Finish	Type / Type	Mounting Hole
ANO 512-512-1018	Nickel	N(jack) /N(jack)	MH 5

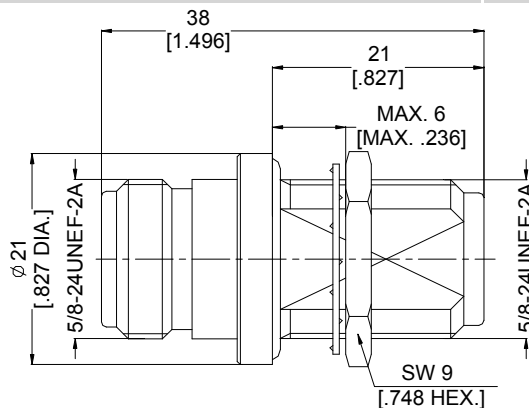

Adapter jack/jack (female/female)

Part No.	Finish	Type / Type
ANO 515-334-1015	Nickel	N(jack) /RP-TNC(jack)

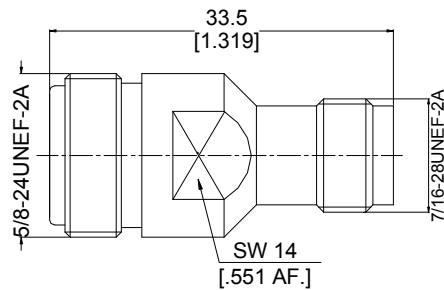

Adapter jack/jack (female/female)

Part No.	Finish	Type / Type
ANO 512-212-1025	Nickel	N(jack) /SMA(jack)

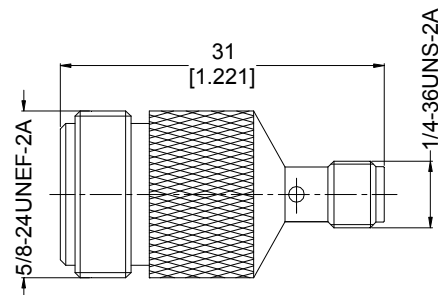

Adapter jack/jack (female/female)

Part No.	Finish	Type / Type
ANO 512-262-1034	Nickel	N(jack) /QMA(jack)

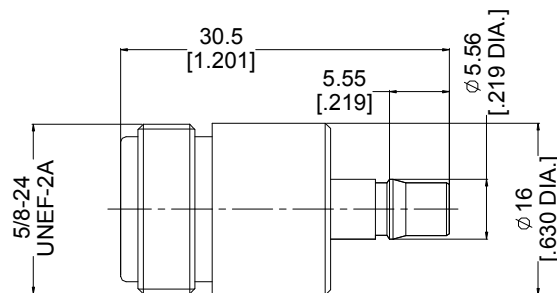

Adapter jack/jack (female/female)

Part No.	Finish	Type / Type
ANO 512-282-1056	Nickel	N(jack) /Mini-QMA(jack)

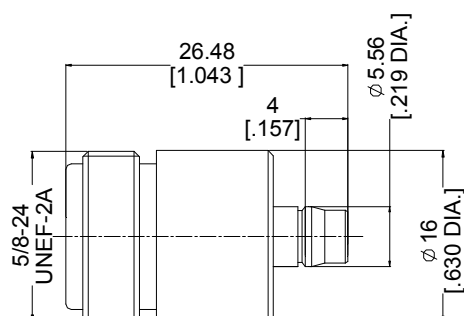

Adapter jack/jack (female/female)

Part No.	Finish	Type / Type
ANO 512-532-1045	Nickel	N(jack) /HPQN(jack)

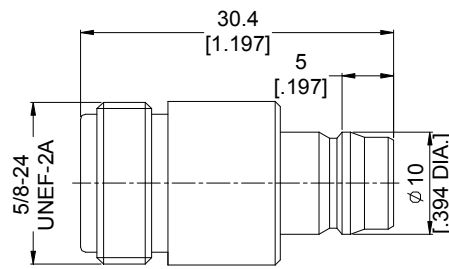

Adapter plug/jack (male/female)

Part No.	Finish	Type / Type
ANO 512-971-1012	Tin	N(jack) /F(plug)

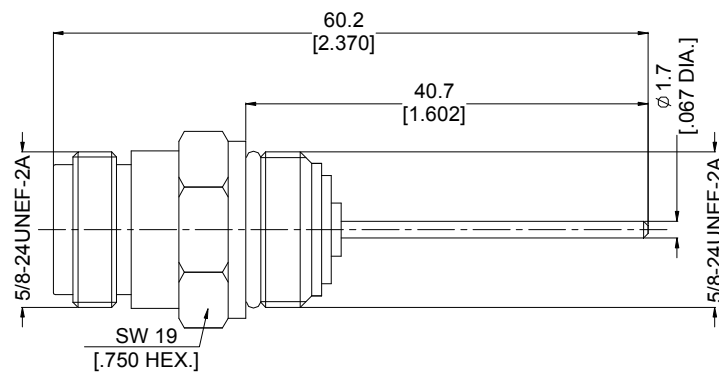

Adapter plug/jack (male/female)

Part No.	Finish	Type / Type
ANO 511-214-1010	Nickel	N(plug) /RP-SMA(jack)
ANO 511-212-1024	Nickel	N(plug) / SMA(jack)

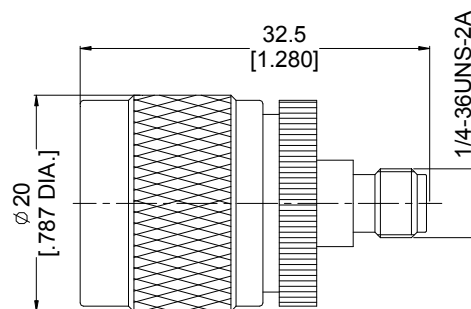

Adapter plug/jack (male/female)

Part No.	Finish	Type / Type
ANO 511-332-1016	Nickel	N(plug) / TNC(jack)

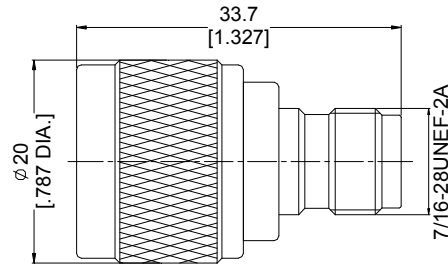

Adapter plug/jack (male/female)

Part No.	Finish	Type / Type
ANO 512-331-1011	Nickel	N(jack) / TNC(plug)

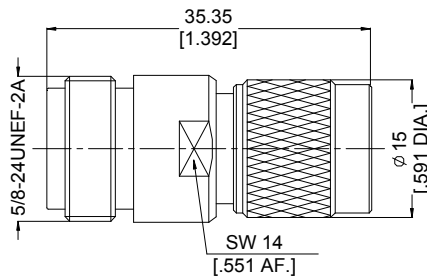

Adapter plug/jack (male/female)

Part No.	Finish	Type / Type
ANO 511-262-1036	Nickel	N(plug) / QMA(jack)

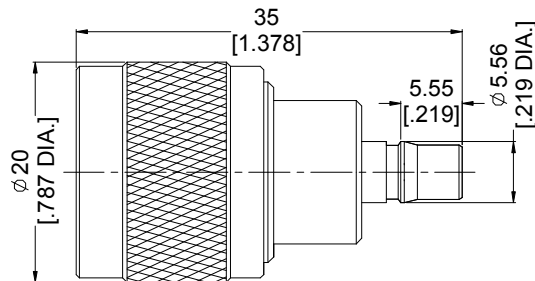

Adapter plug/jack (male/female)

Part No.	Finish	Type / Type
ANO 512-261-1035	Nickel	N(jack) / QMA(plug)

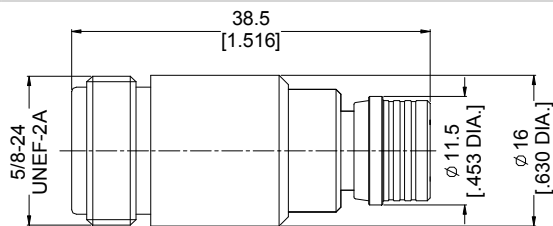

Adapter plug/jack (male/female)

Part No.	Finish	Type / Type
ANO 511-282-1058	Nickel	N(plug) / Mini-QMA(jack)

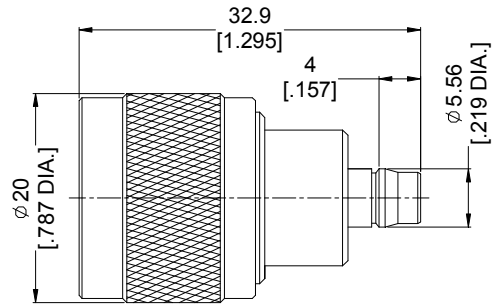

Adapter plug/jack (male/female)

Part No.	Finish	Type / Type
ANO 512-281-1057	Nickel	N(jack) / Mini-QMA(plug)

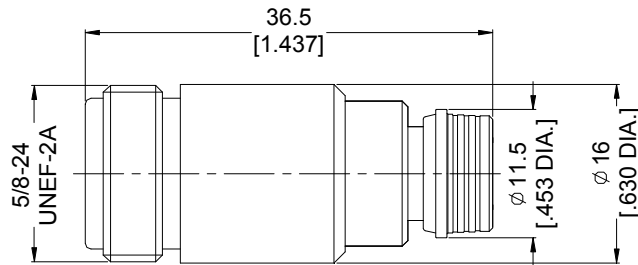

Adapter plug/jack (male/female)

Part No.	Finish	Type / Type
ANO 511-532-1047	Nickel	N(plug) / HPQN(jack)

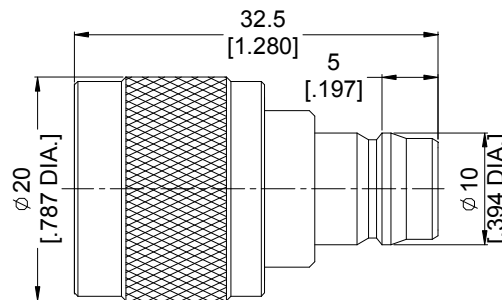

Adapter plug/jack (male/female)

Part No.	Finish	Type / Type
ANO 512-531-1046	Nickel	N(jack) / HPQN(plug)

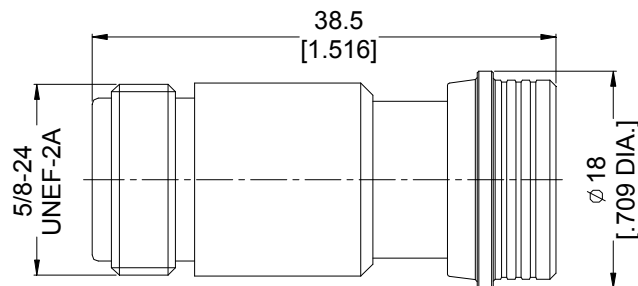

Termination

Straight Plugs (male)

Part No.	Finish	Average Power	Peak Power	Frequency
ANO 511-703	Nickel	1W	2500W	0-4 GHz

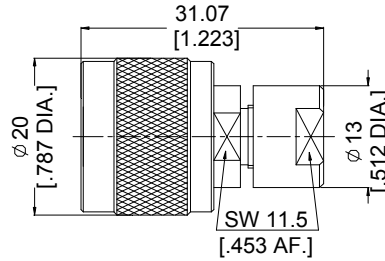

Straight Plugs (male)

Part No.	Finish	Average Power	Peak Power	Frequency
ANO 511-701	Nickel	5W	1000W	0-6 GHz

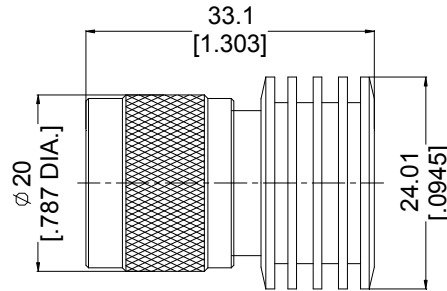

Straight Plugs (male)

Part No.	Finish	Average Power	Peak Power	Frequency
ANO 511-702	Nickel	25W	500W	0-2 GHz

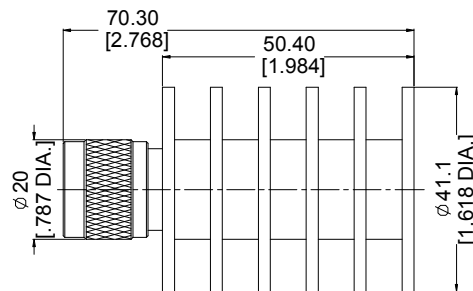

Assembly Instruction

AI 01

Part No.	Cable Group (Example)	Stripping Length a
ANO 5111-2034	.141/50 (SMT680-141/RG402)	5.5

①

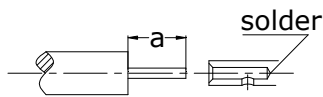

- 1.1 Strip the cable.
- 1.2 Slide on centre contact until it bottoms against cable dielectric.
- 1.3 Solder center contact.
- 1.4 Clean soldering area.

②

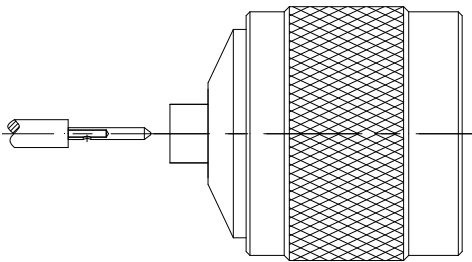

- 2.1 Slide the cable into the body until it bottoms against insulator.

③

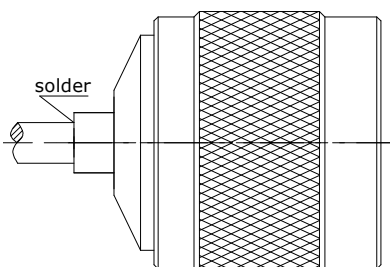

- 3.1 Solder the body onto the cable.
- 3.2 Clean soldering area.

AI 02

Part No.	Cable Group (Example)	Stripping Length		
		a	b	c
ANO 5111-2039	2/50/S (RG78)	2.5	1.8	8.7

①

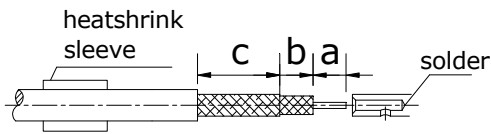

②

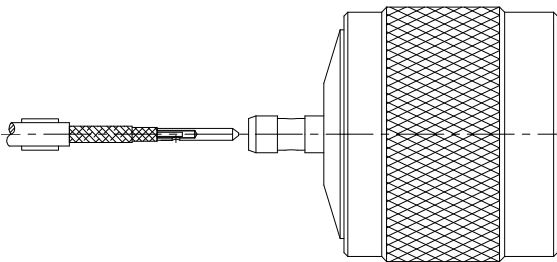

③

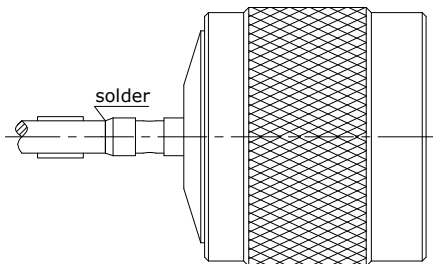

④

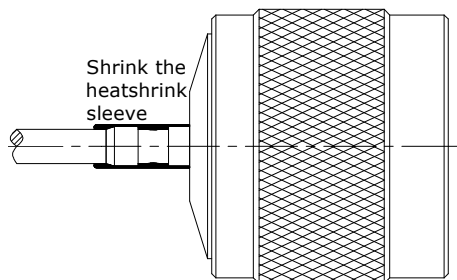

- 1.1 Slide onto the cable the heatshrink sleeve.
- 1.2 Strip the cable.
- 1.3 Slide on center contact until it bottoms against cable dielectrique.
- 1.4 Solder center contact.

- 2.1 Slide the cable into the body until it bottoms against insulator.

- 3.1 Solder the body onto the cable.

- 4.1 Slide sleeve over soldering area and heatshrink in place.

AI 03

Part No.	Cable Group (Example)	Stripping Length		
		a	b	c
ANO 5111-2006	2.6/50/S/D (RG316/LMR100)	2.5	3.0	7.0
ANO 5111-2002	5/50/S/D (R68/LMR200)	2.5	3.0	8.0
ANO 5111-2003	6/50 /D (LMR240)	2.5	2.0	9.0
ANO 5111-2028	15/50 /D (LMR600)	6.0	4.0	14.0

①

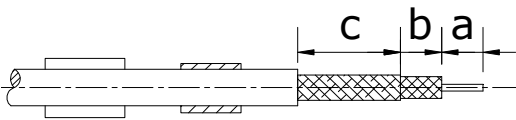

②

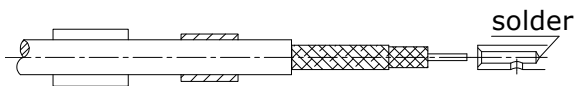

③

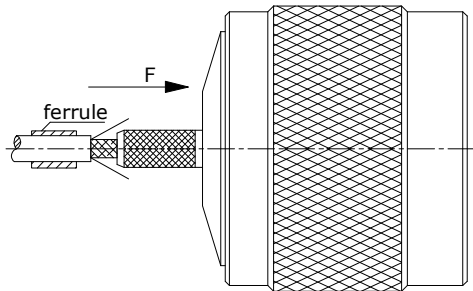

④

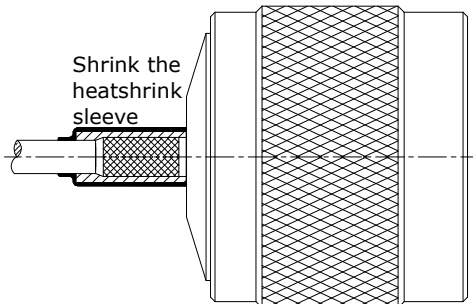

- 1.1 Slide onto the cable the heatshrink sleeve and the ferrule.
- 1.2 Strip the cable.

- 2.1 Slide on center contact until it bottoms against cable dielectrique.
- 2.2 Solder center contact.

- 3.1 Fan the braid.
- 3.2 Slide the cable into the body until it bottoms against insulator.
- 3.3 Slide the ferrule over the braid.
(In direction F)

- 4.1 Cut the excess of braid.
- 4.2 Crimp the ferrule.
- 4.3 Slide sleeve over ferrule and heatshrink in place.

AI 04

Part No.	Cable Group (Example)	Stripping Length		
		a	b	c
ANO 5111-2007	5/50/S/D (R68/LMR195)	5.5	2.0	9.0
ANO 5111-2037	7.5/50 /D (LMR300)	5.5	2.5	10.0
ANO 5112-2038				
ANO 5111-2001	10.5/50 /D (LMR400)	5.4	2.6	10.0
ANO 5112-2025				

①

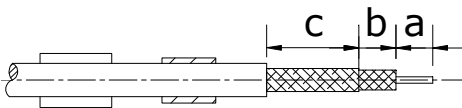

②

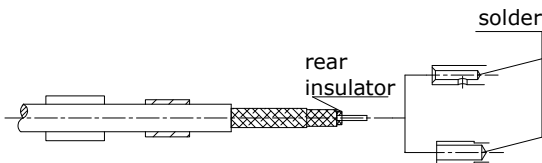

③

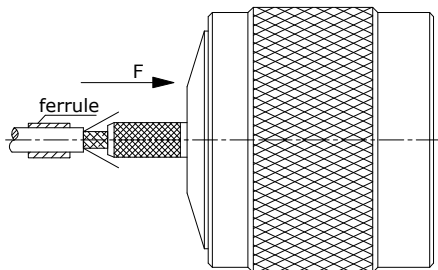

④

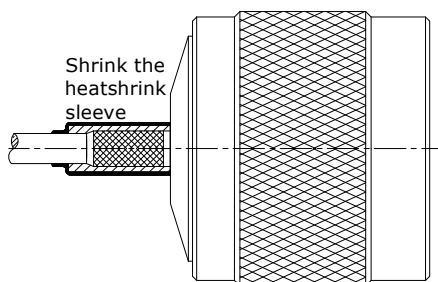

- 1.1 Slide onto the cable the heatshrink sleeve and the ferrule.
- 1.2 Strip the cable.

- 2.1 Slide on rear insulator and center contact.
- 2.2 Solder center contact.

- 3.1 Fan the braid.
- 3.2 Slide the cable into the body until it bottoms against insulator.
- 3.3 Slide the ferrule over the braid.
(In direction F)

- 4.1 Cut the excess of braid.
- 4.2 Crimp the ferrule.
- 4.3 Slide sleeve over ferrule and heatshrink in place.

AI 05

Part No.	Cable Group (Example)	Stripping Length		
		a	b	c
ANO 5121-2041	7.5/50 /D (LMR300)	3.0	8.0	9.0

①

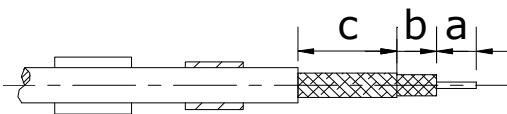

- 1.1 Slide onto the cable the heatshrink sleeve and the ferrule.
- 1.2 Strip the cable.

②

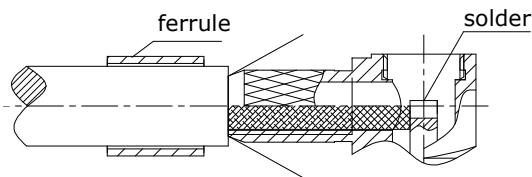

- 2.1 Fan the braid.
- 2.2 Push connector body under the braid.
- 2.3 solder inner conductor.
- 2.4 Slide the ferrule over the braid.

③

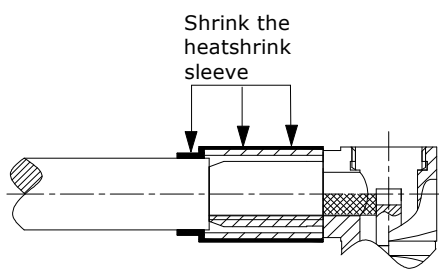

- 3.1 Cut the excess of braid.
- 3.2 Crimp the ferrule.
- 3.3 Slide sleeve over ferrule and heatshrink in place.

④

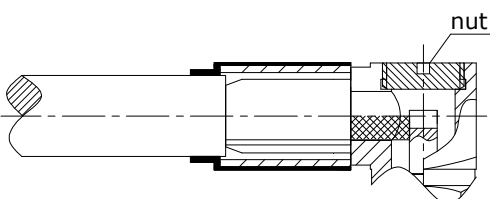

- 4.1 Screw the nut into the body.

AI 06

Part No.	Cable Group (Example)	Stripping Length		
		a	b	c
ANO 5121-2040	10.5/50 /D (LMR400)	6.5	10.0	12.0

①

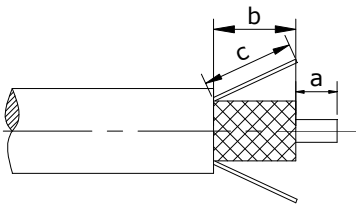

1.1 Strip the cable.

②

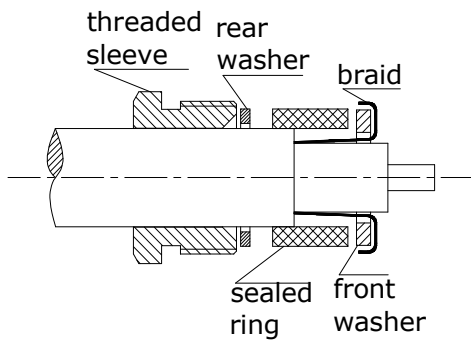

2.1 Slide the threaded sleeve, rear washer, sealed ring and front washer onto the cable.

2.2 Fold back braid and trim off excess of braid.

③

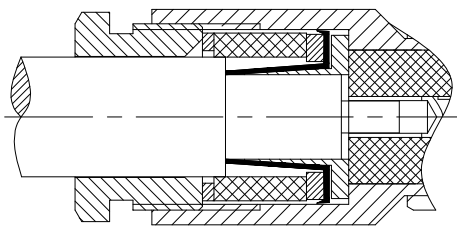

3.1 Screw sub-assembly into the connector body.

AI 07

Part No.	Cable Group (Example)	Stripping Length a
ANO 5112-1018	.083/.085/50 (SMT680-086/RG405)	4.1
ANO 5112-1024		

①

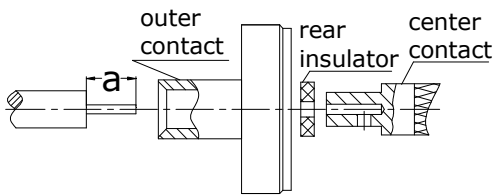

- 1.1 Strip the cable.
- 1.2 Slide onto the cable the outer contact, the rear insulator and the center contact.
- 1.3 Solder center contact.

②

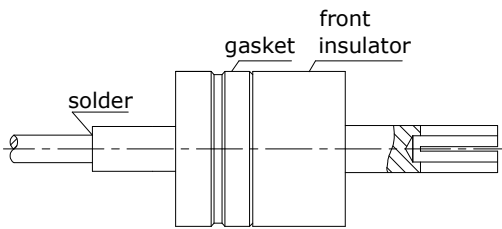

- 2.1 Solder the cable onto the outer contact.
- 2.2 Mount the gasket and the front insulator.

③

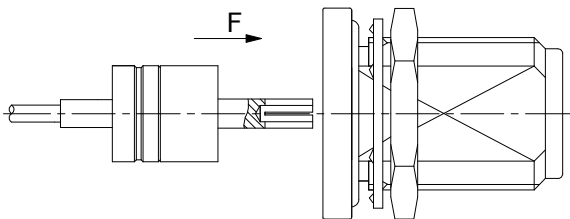

- 3.1 Slide the completed cable into the body.
(In direction F)

④

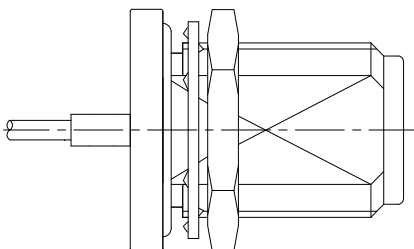

- 4.1 Press the two parts together.

AI 08

Part No.	Cable Group (Example)	Stripping Length		
		a	b	c
ANO 5112-1008	2/50/S (RG78)	3.0	2.0	11.3

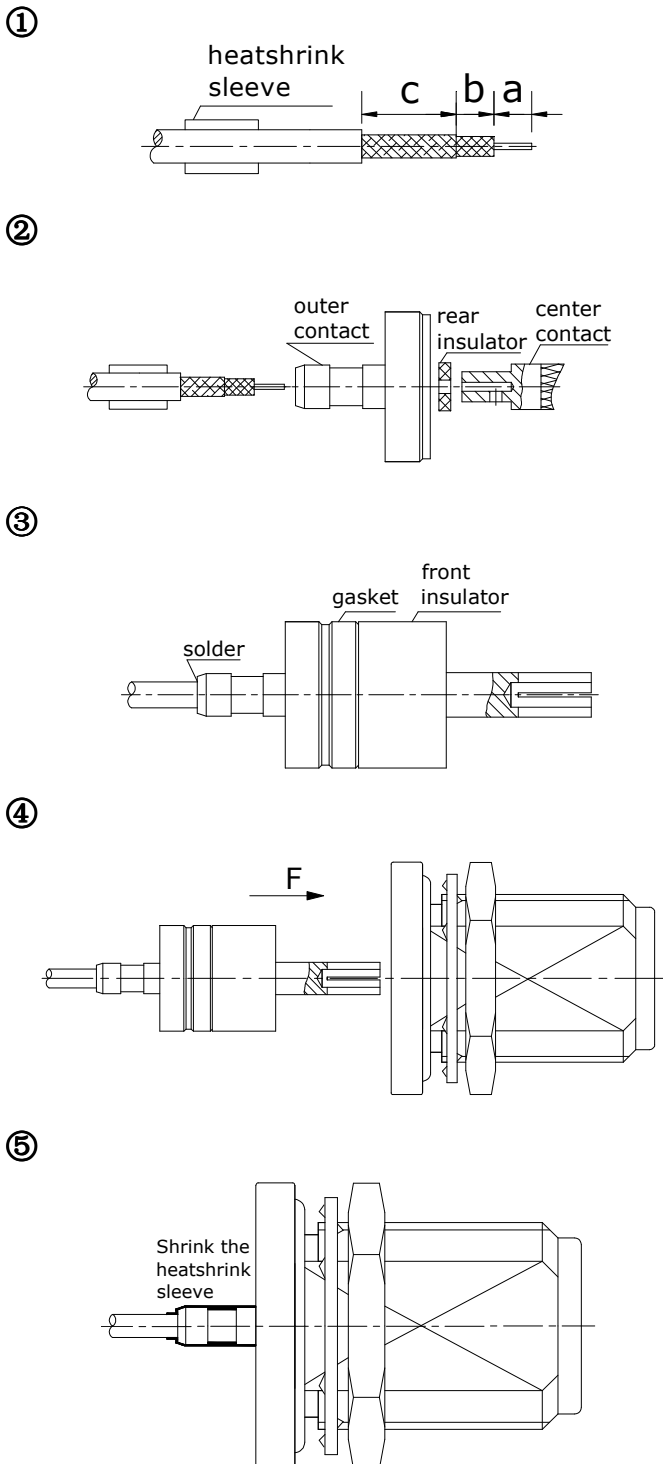

- 1.1 Slide onto the cable the heatshrink sleeve.
- 1.2 Strip the cable.

- 2.1 Slide onto the cable the outer contact, the rear insulator and the center contact.
- 2.2 Solder center contact.

- 3.1 Solder the cable onto the outer contact.
- 3.2 Mount the gasket and the front insulator.

- 4.1 Slide the completed cable into the body.
(In direction F)
- 4.2 Press the two parts together.

- 5.1 Slide sleeve over soldering area and heatshrink in place.

AI 09

Part No.	Cable Group (Example)	Stripping Length		
		a	b	c
ANO 5112-1010	2.6/50/S/D (RG316/LMR100)	4.0	2.2	7.0
ANO 5112-1009	5/50/S/D (RG58/LMR195)	3.0	4.0	8.5

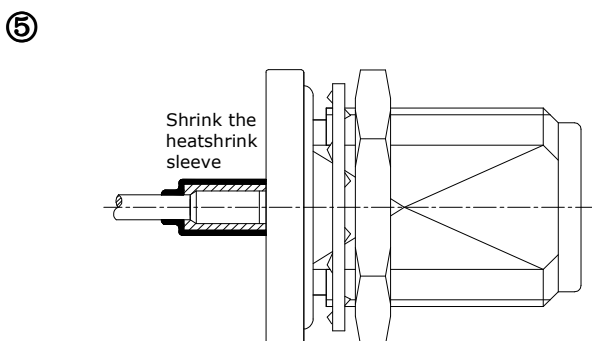
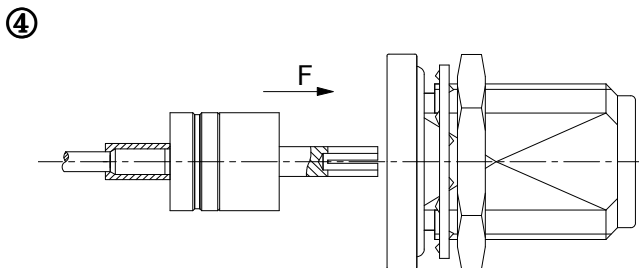
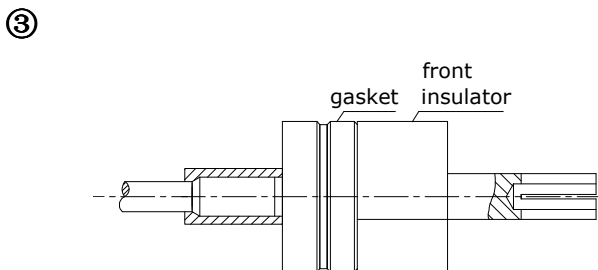
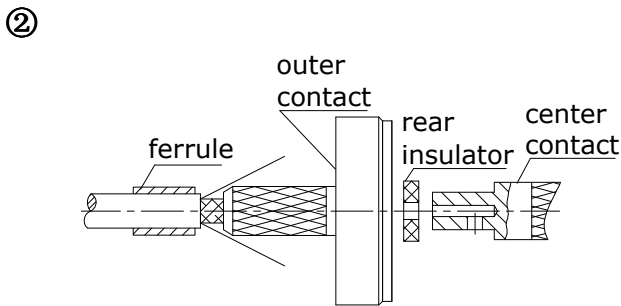
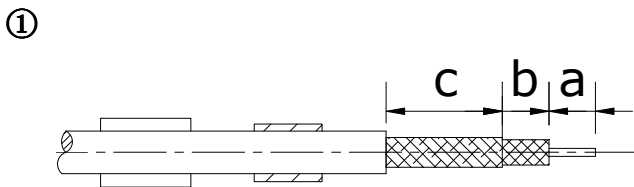

- 1.1 Slide onto the cable the heatshrink sleeve and the ferrule.
- 1.2 Strip the cable.

- 2.1 Fan the braid.
- 2.2 Slide onto the cable the outer contact.
- 2.3 Slide the ferrule over the braid.
- 2.4 Slide onto the cable the rear insulator and the center contact.
- 2.5 Solder center contact.

- 3.1 Cut the excess of braid.
- 3.2 Crimp the ferrule.
- 3.3 Mount the gasket and the front insulator.

- 4.1 Slide the completed cable into the body.
(In direction F)
- 4.2 Press the two parts together.

- 5.1 Slide sleeve over ferrule and heatshrink in place.